

Product Brochure For C156

Lever Block - HLB500

500 KG x 1.5 Metre



Ex GST
\$156.00

Inc GST
\$179.40

ORDER CODE:	C156
MODEL:	HLB500
Lift Capacity (kg / Tonne):	500 / 0.5
Lift Height (Metre):	1.5
Weight (kg):	2.8

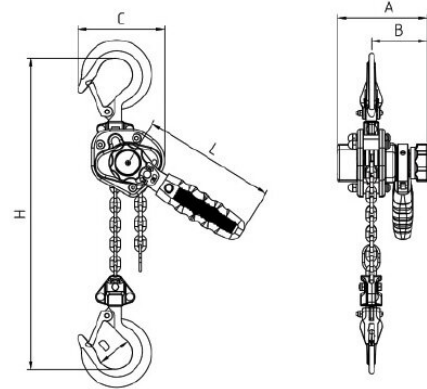

Description

HAFCO 500kg Lever Blocks are lightweight, compact, and ideal for rigging, construction, and mining applications. They feature a Grade 80 alloy load chain and a robust, space-saving steel body. The ID plates are made from stainless steel, and the unit contains no aluminium components. Each unit is AS 1418.2 compliant and supplied with a test certificate for quality assurance.

MODEL	HLB250	HLB500
Capacity (kg)	250kg	500kg
Standards Lift (m)	1.5	1.5
Test Load (Tonne)	0.25	0.5
Headroom H (mm)	230	250
Effort on Lever to lift full load (N)	200	240
No. of chain falls	1	1
Dimensions (mm)	A (mm)	106
	B (mm)	66
	C (mm)	90
	D (mm)	32
Chain Size	4x12	4.3x12
Net Weight (kg)	2.3	2.8

Features

- Rated capacity: 500kg
- Ergonomically compact design
- Built for durability in harsh and rugged environments
- Quick and easy chain adjustment for fast load positioning
- Suitable for use in underground mining and heavy-duty applications
- Ball bearing-mounted to bottom hook enable smooth rotation under load
- Tested at a NATA-accredited facility in accordance with AS 1418.2
- Fully enclosed design with sealed gear and brake systems for superior protection and durability
- The short arm lever and precision gear ratio allow minimal effort to lift heavy loads with maximum
- HAFCO ID plates and rivets are made from stainless steel a non-conductive material for added safety and durability
- Each HAFCO Lever Block is load-tested to its rated capacity and supplied with a HAFCO test certificate, traceable to its stamped identification side plate
- Standard Lift -(Metres) 1.5
- Test Load - (Tonne) 0.5
- Headroom - (H mm) 250
- Effort on lever to lift full load - (N) 240
- No. of chain falls - 1
- Chain Size (mm) - 4.3x12
- Length of lever handle - (L) 160mm

Product Brochure For C156

•
Specific Features



Main View Handle Down



Side View



Front View



Lever Handle Mechanism



Bottom Hook Assembly

Recommended Accessories

H300
Round Sling

H316
Flat Sling

H305
Round Sling

H318
Flat Sling



Product Brochure For C156

H308
Round Sling



H307
Round Sling



H320
Flat Sling



H310
Round Sling



H314
Round Sling



H322
Flat Sling



H312
Round Sling



H324
Flat Sling



C146
Girder Clamp



C147
Girder Trolley



C148
Girder Trolley



C188
Mobile Girder Rail Gantry



Product Brochure For C156

K088

Mobile Girder Rail Gantry
Package Deal

K090

Mobile Girder Rail Gantry
Package Deal

