

Product Brochure For C1011

## MP-36224M - Straight Line with Threaded Collar Toggle Clamp

690kg Capacity

**On Sale**

**Ex GST**  
~~\$36.00~~  
**\$29.57**

**Inc GST**  
~~\$41.40~~  
**\$34.00**

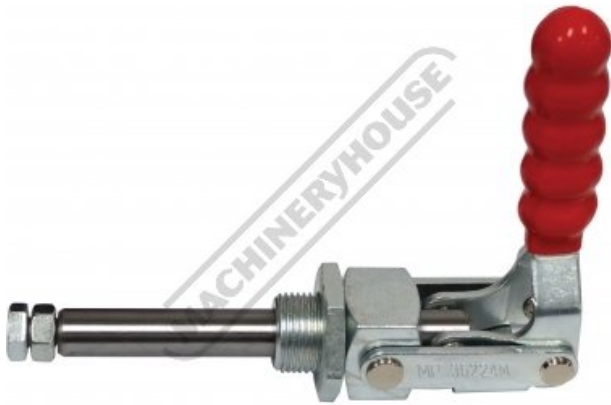

ORDER CODE:	C1011
MODEL:	MP-36224M
Type:	Straight Line Toggle Clamp
Clamping Capacity:	
Locking Handle - Pivot Movement:	180°
Clamp Bar - Pivot Movement:	~
Plunger Travel (mm):	67
Throat Depth (mm):	~
Opening (mm):	~
Size:	~
Quantity Per Pack (No.):	1
Clamping Force (kg):	690kg
Over all Length (mm):	~
Nett Weight (kg):	0.7



### Features

- MP-36224M - Straight Line with Threaded Collar Toggle Clamp
- Holding capacity: 690kg
- Handle moves: 180°
- Plunger travel: 67mm
- Weight: 700g

Product Brochure For C1011

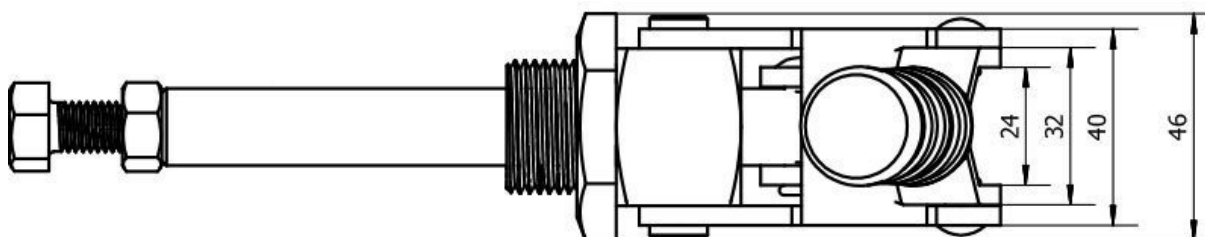
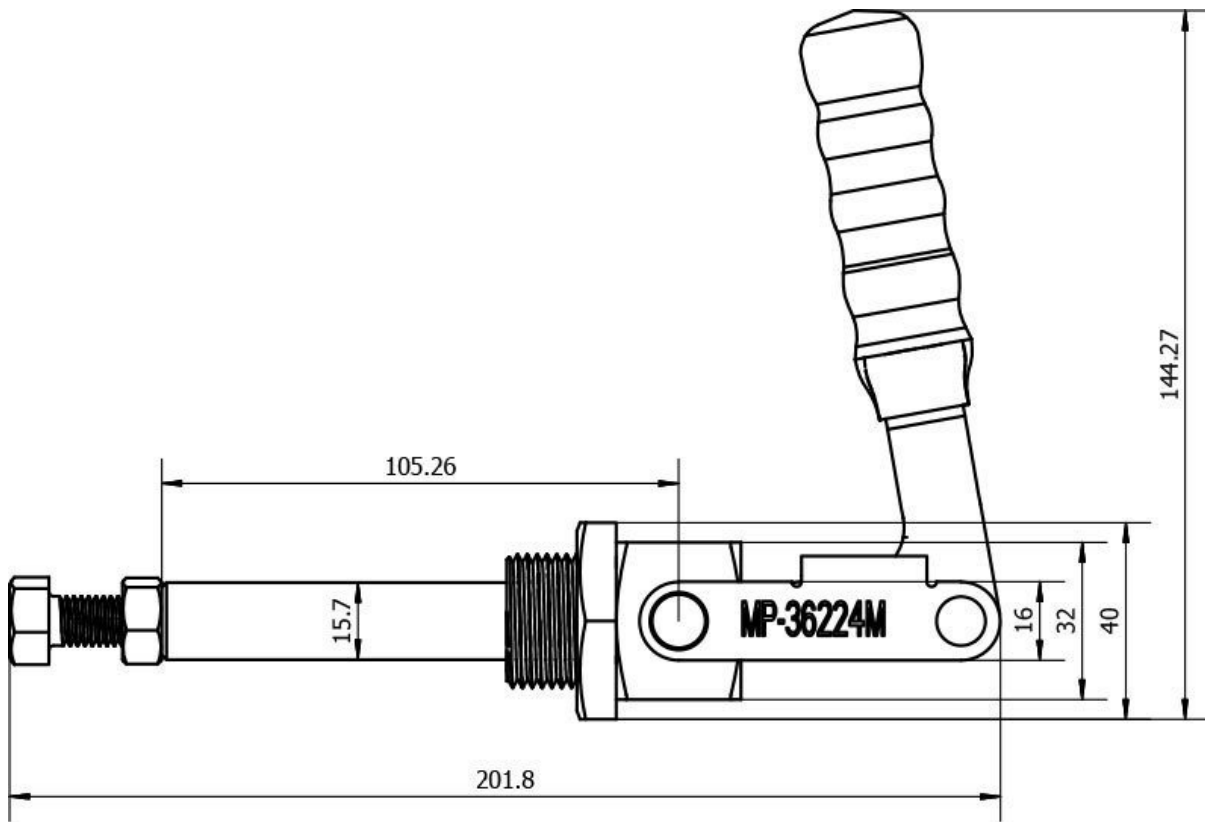

Product Brochure For C1011

---

**Specific Features**



Open

**Recommended Accessories**

C1001  
Vertical Toggle Clamp



C100  
Vertical Toggle Clamp



C0999  
Vertical Toggle Clamp



C0998  
Vertical Toggle Clamp



C1003  
Horizontal Toggle Clamp



C1005  
Horizontal Toggle Clamp



C1006  
Horizontal Toggle Clamp



C1008  
Straight Line Toggle Clamp



Product Brochure For C1011

---

C1009  
Straight Line Toggle Clamp

C1010  
Straight Line Toggle Clamp

