

Product Brochure For C1010

MP-304-HM - Straight Line Toggle Clamp

680kg Capacity

On Sale

Ex GST
\$44.00
\$36.52

Inc GST
\$50.60
\$42.00



ORDER CODE:	C1010
MODEL:	MP-304-HM
Type:	Straight Line Toggle Clamp
Clamping Capacity:	
Locking Handle - Pivot Movement:	190°
Clamp Bar - Pivot Movement:	~
Plunger Travel (mm):	62
Throat Depth (mm):	~
Opening (mm):	~
Size:	~
Quantity Per Pack (No.):	1
Clamping Force (kg):	680kg
Over all Length (mm):	~
Nett Weight (kg):	1.5



Features

- MP-304-HM - Straight Line Toggle Clamp
- Holding capacity: 680kg
- Handle moves: 190°
- Plunger travel: 62mm
- Weight: 1.5kg

Product Brochure For C1010

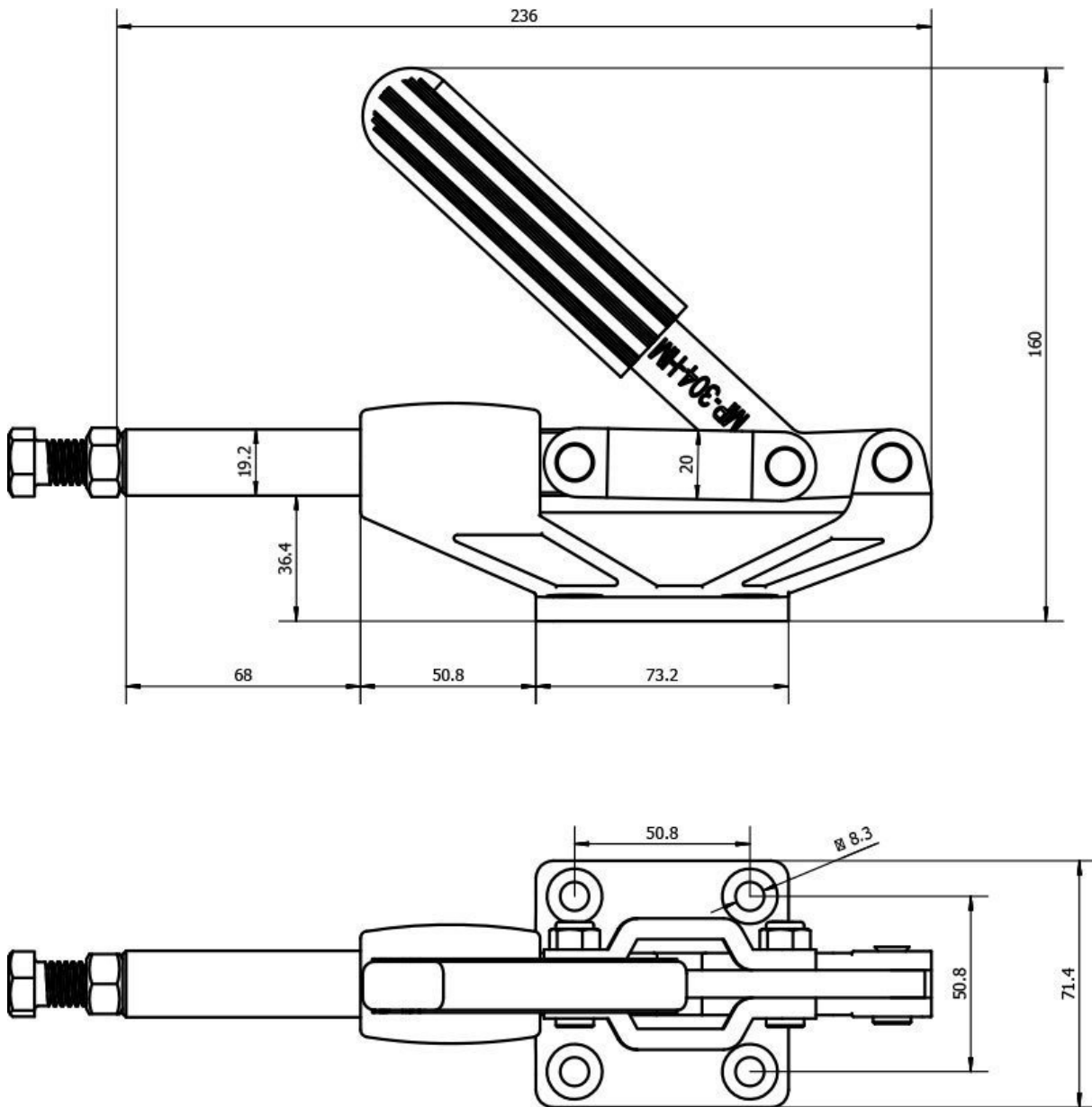

Product Brochure For C1010

Specific Features



Open

Recommended Accessories

C1001
Vertical Toggle Clamp

C100
Vertical Toggle Clamp

C0999
Vertical Toggle Clamp

C0998
Vertical Toggle Clamp



C1003
Horizontal Toggle Clamp

C1005
Horizontal Toggle Clamp

C1006
Horizontal Toggle Clamp

C1008
Straight Line Toggle Clamp



Product Brochure For C1010

C1011

Straight Line with Threaded
Collar Toggle Clamp

C1009

Straight Line Toggle Clamp

