

Product Brochure For A350

HC-1.25T - Hydraulic Engine Crane

1.25 Tonne Lifting Capacity

Ex GST
\$430.00

Inc GST
\$494.50



ORDER CODE:	A350
MODEL:	HC-1.25T
Type:	Engine Crane
Engine Crane Capacity (Tonne):	1.25
Engine Crane Operation (Type):	Hydraulic
Engine Stand Capacity (kg):	~
Trolley Jack Capacity (Tonne):	~
Axle Stand Capacity - Each (Tonne):	~
Mechanics Creeper Capacity (kg):	~
Nett Weight (kg):	92



Description

Every mechanic or home auto restoration enthusiast knows all too well that using the correct tool it always makes the job in hand much easier when it is time to remove or replace an engine in your car.

This is why we ensure the Hafco HC-1.25T engine crane is no light weight & is up to the task. We ensure our design has been independently tested to comply with Australian Standard AS1418.8-2008 to have a working load lift capacity of 1250kg. The Australian Standard requires a safety factor of 200% so don't be fooled by lighter & cheaper ones in the market.

The long extendable jib has four positions with lifting capacity of 310kg, 625kg, 930kg or 1250kg to give you more reach & with the lifting height range from 0-2300mm so an engine can be lifted out of the engine bay with ease. Other features include a double pump cylinder, folding legs with 6 swivel castor wheels & rear T-bar handle enables excellent manoeuvrability around the workshop.

Features

- Tested to comply with Australian Standard AS1418.8-2008
- Double action pump on hydraulic 8 tonne lifting ram
- Adjustable boom in four positions for lifting
- Outrigger legs easily folded up for transport or storage
- Six cast steel swivel caster wheels allow easy mobility
- T-bar handle with grips on rear of hoist allows greater manoeuvrability control

Product Brochure For A350

Specific Features



Features



Double Action Pump



Fold Up Legs for Easy Storage



D shackle



Low View



Quick Release Lock Pins to Legs



Slide Out Jib with 4 WLL Lifting Positions

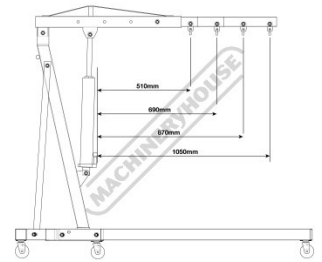

Throat Depth

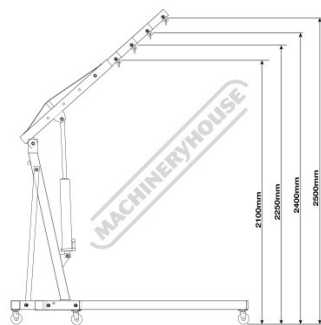

Max Lift Heights

Product Brochure For A350

Recommended Accessories

A3425
Engine Tilter - Heavy Duty



J032
Hydraulic Bottle Jack with Yoke
- 8 Tonne

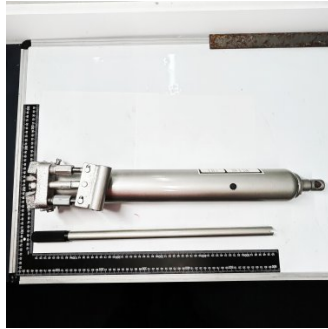

A340
Engine Stand - 907kg Capacity



A341
Engine Stand - 450kg Capacity



A353
Swivel Crane - Truck or Ute



A354
Swivel Crane - Truck or Ute



A385
Steel Gearbox & Engine Tear
Down Table



H300
Round Sling



Product Brochure For A350

H305
Round Sling



H307
Round Sling



H310
Round Sling



H312
Round Sling



H316
Flat Sling



H318
Flat Sling



H320
Flat Sling



H322
Flat Sling



H324
Flat Sling

