

Product Brochure For 5DB0056

MOTOR TAIL CASING - #56

Suits: HF-750

ORDER CODE: _____ ~



Features

- L 10cm x W 11cm x H 5cm
- Weight 1 kg

Specific Features

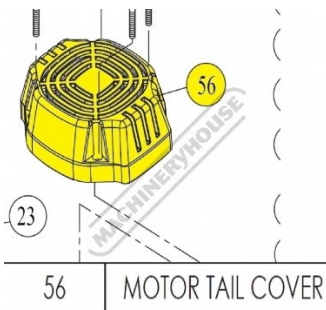

Image 2